

FEATURES

- Roof curb perimeter made of galvanized steel.
- Gasketing package provided.
- Heat treated wood nailer provided.
- Corner flanges are pre-threaded for easy bolt on assembly.
- Pitched, adjustable pitch/adjustable height, welded, different height, isolation and calculated curbs are available.

NOTES

- Attach ductwork to roof curb. Flanges of duct rest on top of the curb. Support ductwork below the curb.

KNOCK-DOWN ROOF CURBS FOR YORK UNITS

P***A ALL MODELS

PROVENT P/N	A	EST. WEIGHT	SEISMIC KIT P/N
CBKDLXS08	8"	43 Lbs.	KDKITLX
CBKDLXS11	11"	54 Lbs.	
CBKDLXS14	14"	65 Lbs.	
CBKDLXS24	24"	104 Lbs.	

When conforming to CBC 2022 and IBC 2021, include optional seismic kit.

Available on 8" - 14"

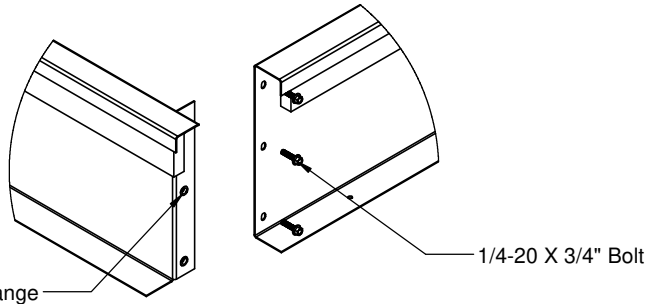
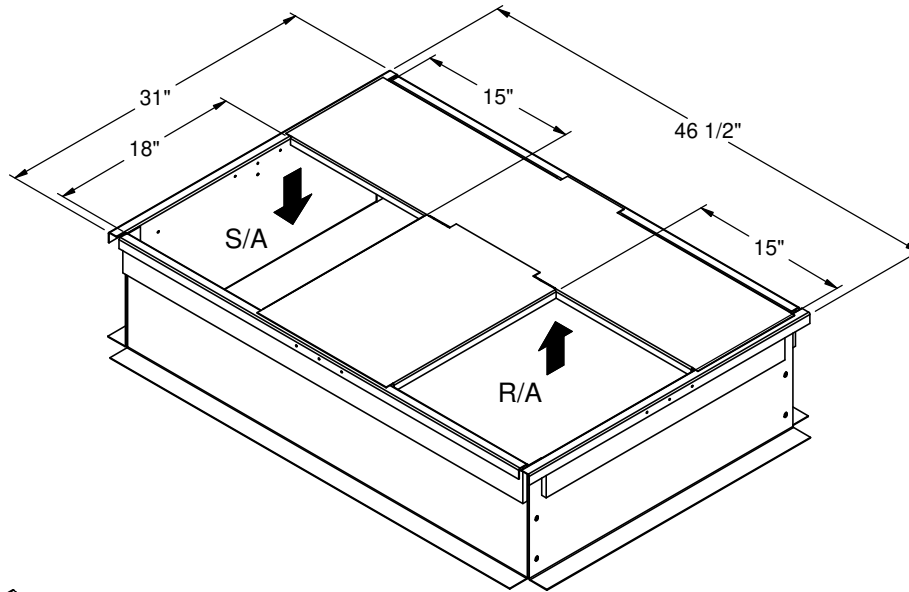

CORNER DETAIL

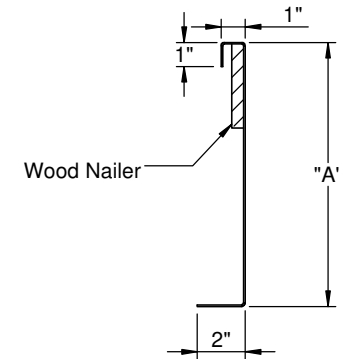

CROSS SECTION DETAIL



3847 WABASH DR.
MIRA LOMA, CA 91725

PHONE (951) 685-1101
FAX (619) 872-9799

SUBMITTED TO: _____
COMPANY: _____
JOB NAME: _____
EQUIPMENT: _____
NOTES: _____

FORM NO:
CBKD-150

DATE:
1/7/2022

PART NUMBER:
CBKDLXS SERIES

REV:
5

DRAWN BY:
JG