

FEATURES

- Roof curb perimeter made of galvanized steel.
- Gasketing package provided.
- Heat treated wood nailer provided.
- Corner flanges are pre-threaded for easy bolt on assembly.
- Pitched, adjustable pitch/adjustable height, welded, different height, isolation and calculated curbs are available.

NOTES

- Attach ductwork to roof curb. Flanges of duct rest on top of the curb. Support ductwork below the curb.

KNOCK-DOWN ROOF CURBS FOR YORK UNITS

ZX08-14; XX08-12; ZY07-12; XY07-09; ZL08-14; XYA7; ZYA7

PROVENT P/N	A	EST. WEIGHT	SEISMIC KIT P/N
CBKDPRL08	8"	100 Lbs.	KDKITPRL
CBKDPRL11	11"	116 Lbs.	
CBKDPRL14	14"	144 Lbs.	
CBKDPRL18	18"	160 Lbs.	
CBKDPRL24	24"	192 Lbs.	

When conforming to CBC 2022 and IBC 2021, include optional seismic kit.

Available on 8" - 14"

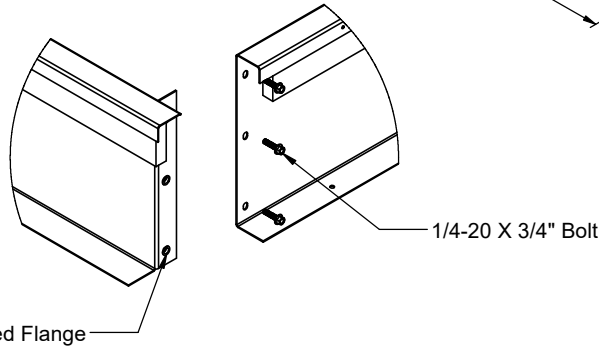
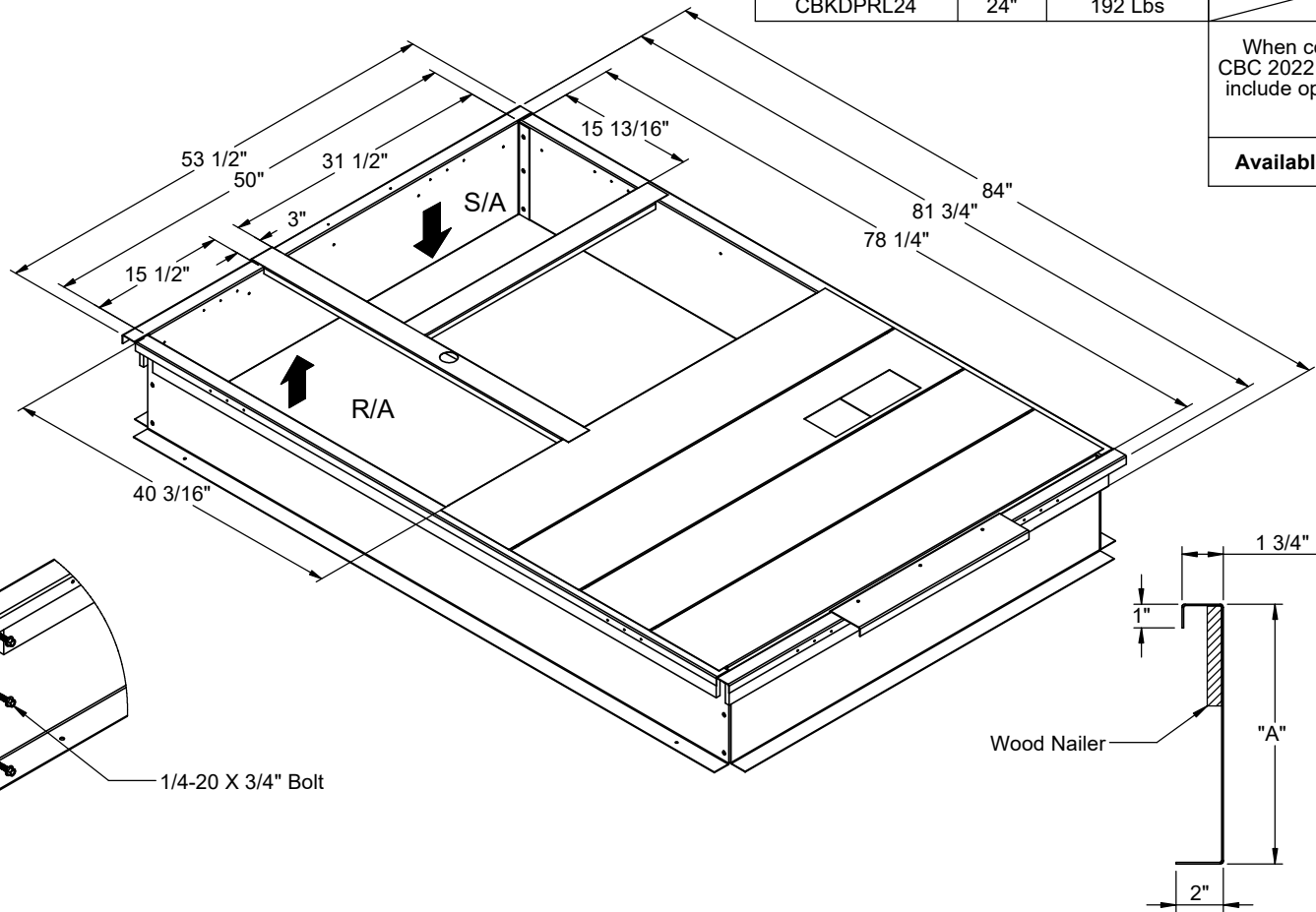

CORNER DETAIL

CROSS SECTION DETAIL



3847 WABASH DR.
MIRA LOMA, CA 91752

PHONE (951) 685-1101
FAX (619) 872-9799

SUBMITTED TO: _____
COMPANY: _____
JOB NAME: _____
EQUIPMENT: _____
NOTES: _____

FORM NO:
CBKD-70

PART NUMBER:
CBKDPRL SERIES

DATE:
9/20/2023

REV:
6

DRAWN BY:
CNG