

FEATURES

- Roof curb perimeter made of galvanized steel.
- Gasketing package provided.
- Heat treated wood nailer provided.
- Corner flanges are pre-threaded for easy bolt on assembly.
- Pitched, adjustable pitch/adjustable height, welded, different height, isolation and calculated curbs are available.

NOTES

- Attach ductwork to roof curb. Flanges of duct rest on top of the curb. Support ductwork below the curb.

KNOCK-DOWN ROOF CURBS FOR YORK UNITS

ZY, ZQ, XY, XQ, ZL04-06; ZX04-07, XXA7, ZXA7

PROVENT P/N	A	EST. WEIGHT	SEISMIC KIT P/N
CBKDPRS08	8"	83 Lbs.	KDKITPRS
CBKDPRS11	11"	89 Lbs.	
CBKDPRS14	14"	105 Lbs	
CBKDPRS18	18"	118 Lbs.	
CBKDPRS24	24"	144 Lbs	

When conforming to CBC 2022 and IBC 2021, include optional seismic kit.

Available on 8" - 14"

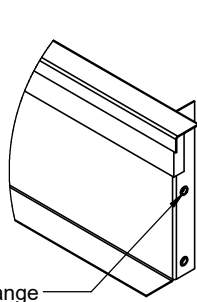
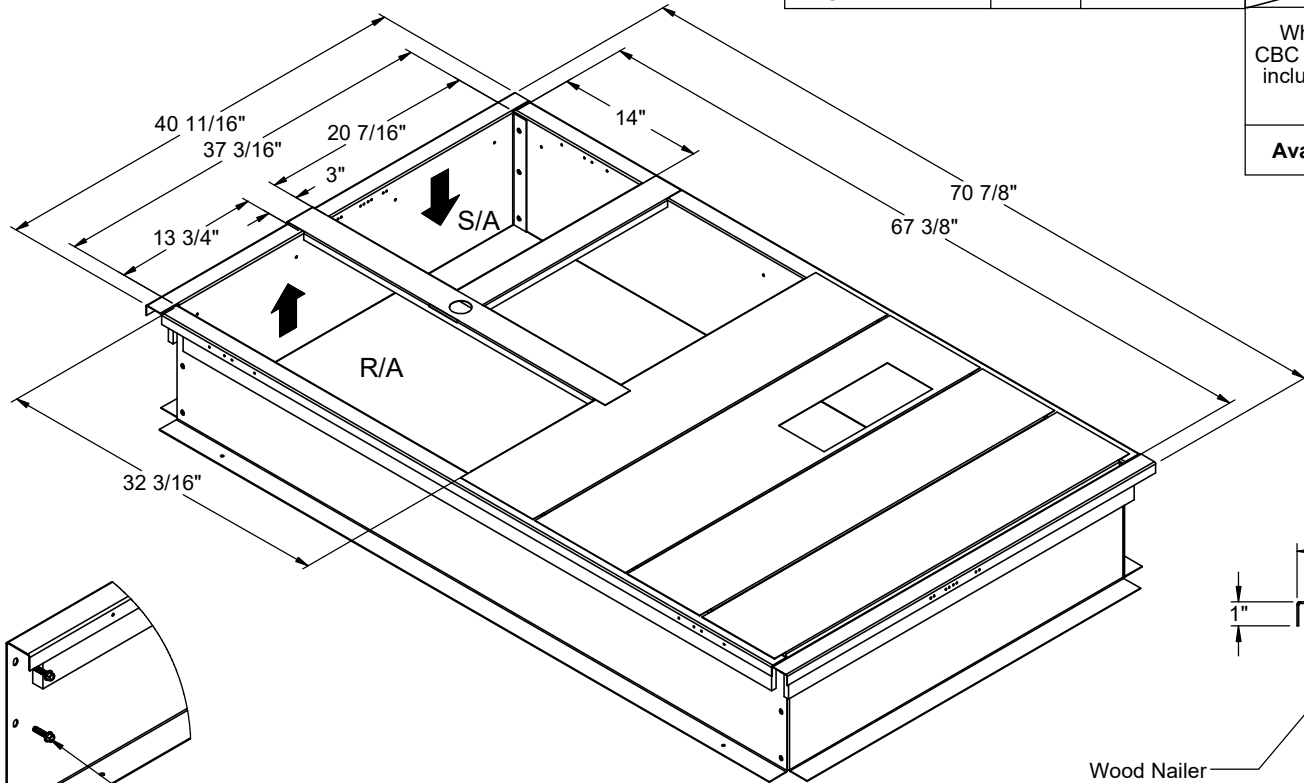

Pre-Threaded Flange

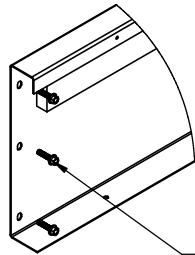

1/4-20 X 3/4" Bolt

CORNER DETAIL

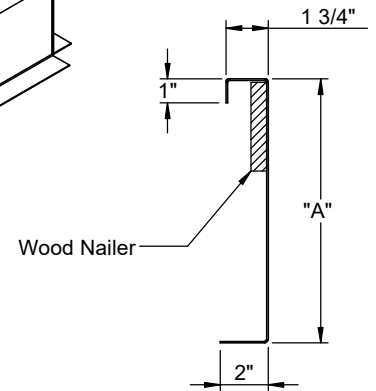

Wood Nailer

CROSS SECTION DETAIL



3847 WABASH DR.
MIRA LOMA, CA 91752

PHONE (951) 685-1101
FAX (619) 872-9799

SUBMITTED TO: _____
COMPANY: _____
JOB NAME: _____
EQUIPMENT: _____
NOTES: _____

FORM NO:
CBKD-71

PART NUMBER:
CBKDPRS SERIES

DATE:
9/20/2023

REV:
8

DRAWN BY:
CNG