

**FEATURES**

- Roof curb perimeter made of 14 ga. galvanized steel.
- Gasketing package provided.
- Heat treated wood nailer provided.
- Corner flanges are pre-threaded for easy bolt on assembly.
- Pitched, adjustable pitch/adjustable height, welded, different height, isolation and calculated curbs are available.

**NOTES**

- Attach ductwork to roof curb. Flanges of duct rest on top of the curb. Support ductwork below the curb.

**KNOCK-DOWN ROOF CURBS FOR YORK UNITS**

ZX 04-07; XXA7, ZXA7; ZY, ZQ, XY, XQ, ZL 04-06

PROVENT P/N	A	EST. WEIGHT	SEISMIC KIT P/N
CBKDPRS08	8"	83 Lbs.	KDKITPRS
CBKDPRS11	11"	94 Lbs.	
CBKDPRS14	14"	105 Lbs	
CBKDPRS24	24"	144 Lbs	

When conforming to CBC 2019 and IBC 2018, include optional seismic kit.

**Available on 8" - 14"**

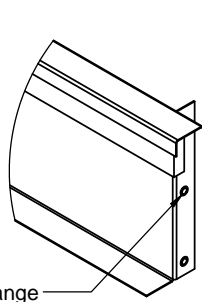
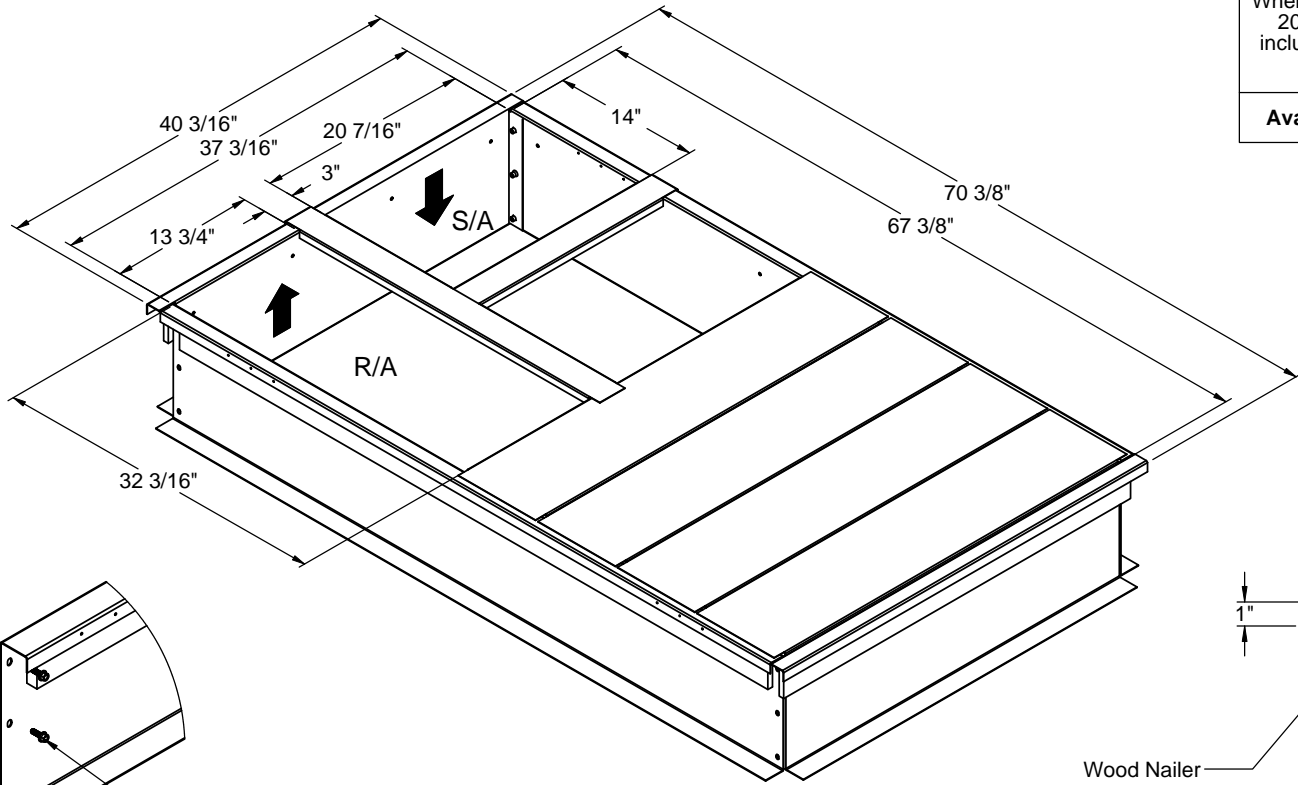

Pre-Threaded Flange

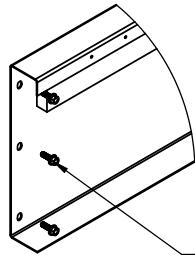

1/4-20 X 3/4" Bolt

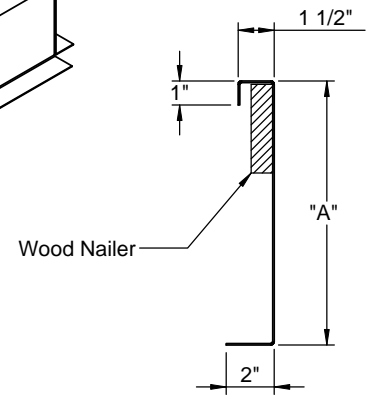

Wood Nailer

**CORNER DETAIL**

**CROSS SECTION DETAIL**



3847 WABASH DR.  
MIRA LOMA, CA 91725

PHONE (951) 685-1101  
FAX (619) 872-9799

SUBMITTED TO: \_\_\_\_\_  
COMPANY: \_\_\_\_\_  
JOB NAME: \_\_\_\_\_  
EQUIPMENT: \_\_\_\_\_  
NOTES: \_\_\_\_\_

FORM NO:  
CBKD-71

PART NUMBER:  
CBKDPRS SERIES

DATE:  
11/7/2022

REV:  
M-1

DRAWN BY:  
CNG