

FEATURES	KNOCK-DOWN ROOF CURBS FOR SUNCHOICE UNITS	General Table		
	15-18	PROVENT P/N	A	EST. WEIGHT

- Roof curb perimeter made of galvanized steel.
- Gasketing package provided.
- Heat treated wood nailer provided.
- Corner flanges are pre-threaded for easy bolt on assembly.
- Pitched, adjustable pitch/ adjustable height, welded, different height, isolation and calculated curbs are available.

CBKDSAV151808**	08"	195 Lbs.
CBKDSAV151811**	11"	225 Lbs.
CBKDSAV151814**	14"	265 Lbs.
CBKDSAV151818**	18"	300 Lbs.

NOTES

- Attach ductwork to roof curb. Flanges of duct rest on top of curb. Support ductwork below the curb.

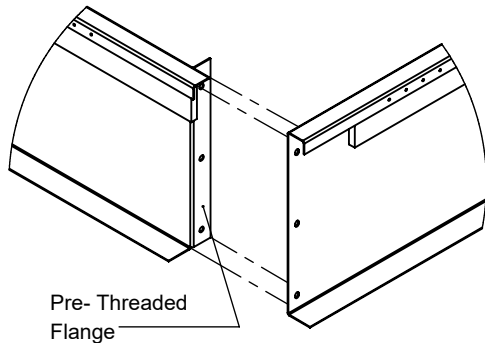
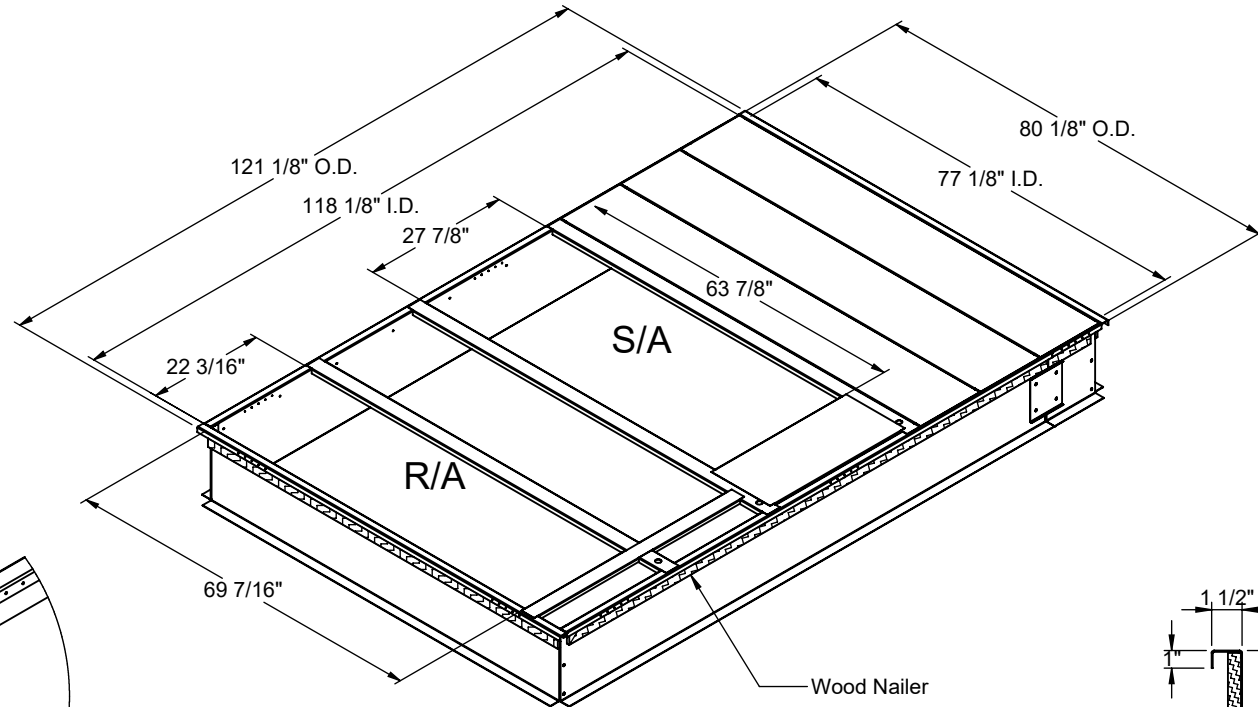

CORNER DETAIL

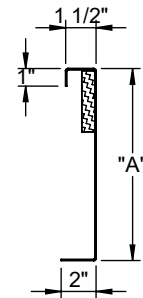

CROSS SECTION DETAIL

	3847 WABASH DRIVE MIRA LOMA, CA 91725	SUBMITTED TO: _____ COMPANY: _____ JOB NAME: _____ EQUIPMENT: _____ NOTES: _____	FORM NO: -	PART NUMBER: CBKDSAV1518 SERIES
	PHONE (951) 685-1101 FAX (619) 872-9799	DATE: 4/9/2020	REV: -	DRAWN BY: ALL