

FEATURES	KNOCK-DOWN ROOF CURBS FOR SUNCHOICE UNITS	PROVENT P/N	A	EST. WEIGHT	Seismic Kit PN
		CBKDSAV151808**	08"	195 Lbs.	KDKITSAV1518
		CBKDSAV151811**	11"	225 Lbs.	
		CBKDSAV151814**	14"	265 Lbs.	
		CBKDSAV151818**	18"	305 Lbs.	When conforming to CBC 2022 and IBC 2021, include optional seismic kit.
CBKDSAV151824**	24"	346 Lbs.	Available for 8" - 18"		

AV 15-18, AD 15-18; AH 15, AL 15, HV13

- Roof curb perimeter made of galvanized steel.
- Gasketing package provided.
- Heat treated wood nailer provided.
- Corner flanges are pre-threaded for easy bolt on assembly.
- Pitched, adjustable pitch/ adjustable height, welded, different height, isolation and calculated curbs are available.

- NOTES**
- Attach ductwork to roof curb. Flanges of duct rest on top of curb. Support ductwork below the curb.

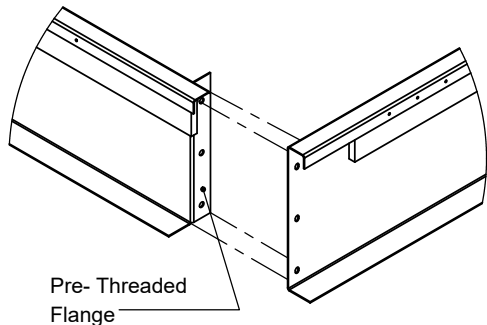
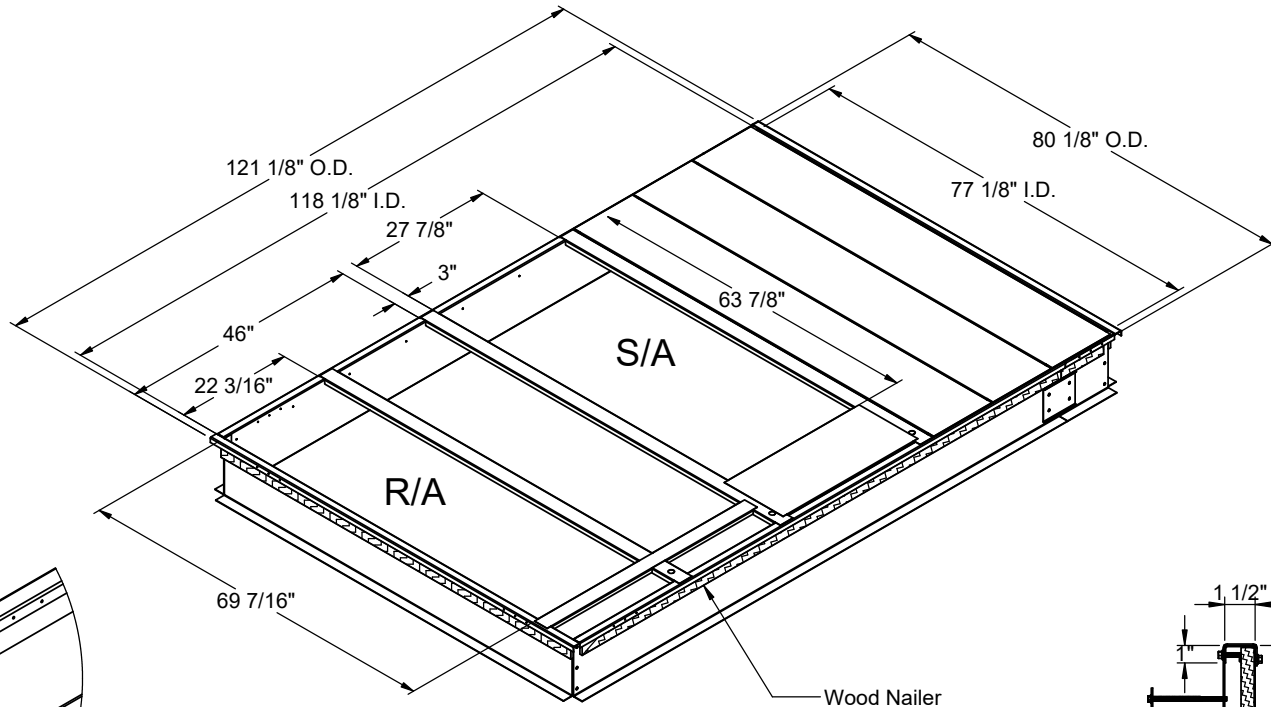

CORNER DETAIL

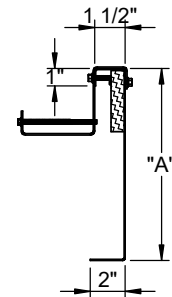

CROSS SECTION DETAIL

CBKDSAV151818 will be 12Ga perimeter



3847 WABASH DRIVE
MIRA LOMA, CA 91752

PHONE (951) 685-1101
FAX (619) 872-9799

SUBMITTED TO: _____
COMPANY: _____
JOB NAME: _____
EQUIPMENT: _____
NOTES: _____

FORM NO:
-

DATE:
8/7/2023

PART NUMBER:
CBKDSAV1518 SERIES

REV:
2

DRAWN BY:
JG