

For wood, concrete, and steel attachments, see Roof Anchorage Detail, Form no. CB-60.

### KNOCK-DOWN ROOF CURBS FOR YORK UNITS

P\*\*\*B ALL MODELS

PROVENT P/N	A	EST. WEIGHT	SEISMIC KIT P/N	WEIGHT
CBKDLXL08	8"	53 Lbs.	KDKITLX	5 Lbs.
CBKDLXL11	11"	64 Lbs.		
CBKDLXL14	14"	75 Lbs.		

Meets seismic requirements for the following codes:  
CBC 2022  
IBC 2021

Will conform to seismic code requirements for knock-down or pre-assembled application. (Contact factory for assembled version.)

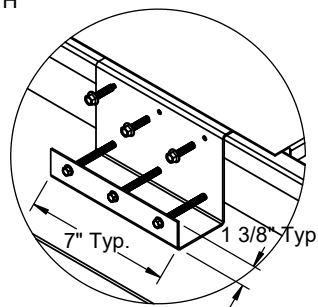
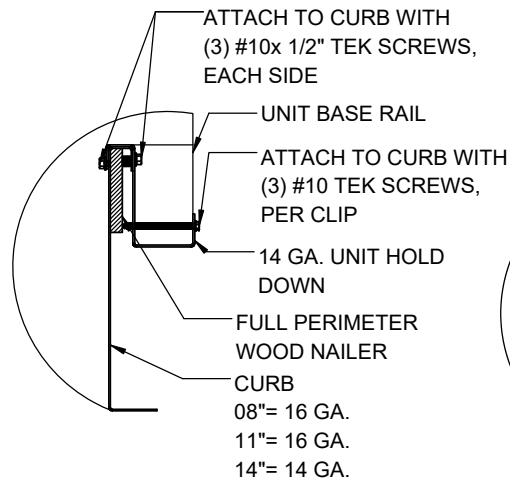
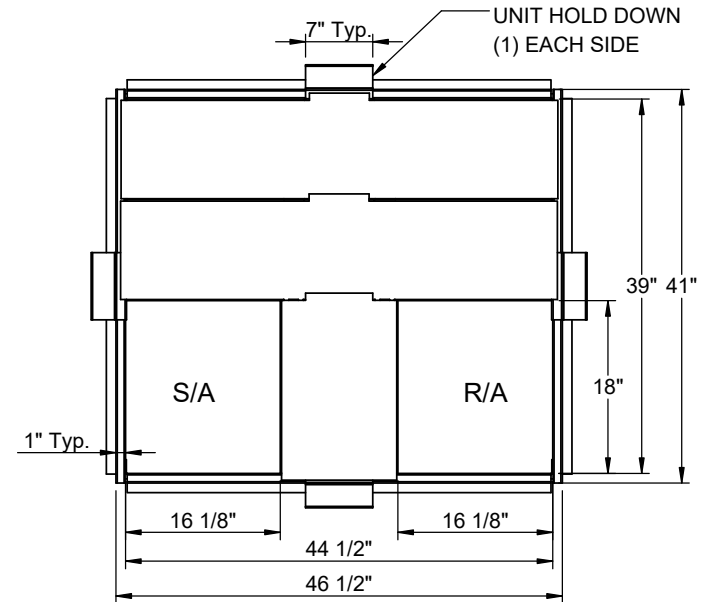
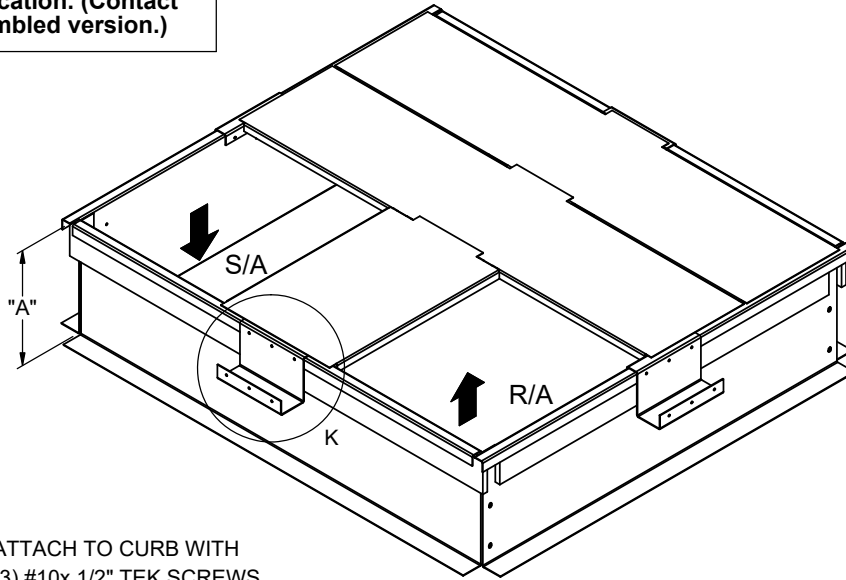

1/4"-20 THREADED INSERT  
(2) (A= 8")  
(3) (A> 8")

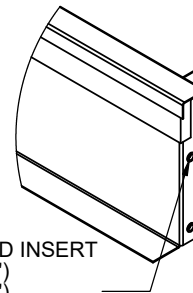

**CORNER DETAIL**



**HOLD DOWN DETAIL**

**DETAIL K**



3847 WABASH DR.  
MIRA LOMA, CA 91752

PHONE (951) 685-1101  
FAX (619) 872-9799

SUBMITTED TO: \_\_\_\_\_  
COMPANY: \_\_\_\_\_  
JOB NAME: \_\_\_\_\_  
EQUIPMENT: \_\_\_\_\_  
NOTES: \_\_\_\_\_

FORM NO:  
CBKD-153

DATE:  
7/13/2023

PART NUMBER:  
KDKITLXL SERIES

REV:  
8

DRAWN BY:  
JG