

For wood, concrete, and steel attachments, see Roof Anchorage Detail, Form no. CB-60.

KNOCK-DOWN ROOF CURBS FOR YORK UNITS

P***A ALL MODELS

PROVENT P/N	A	EST. WEIGHT	SEISMIC KIT P/N	WEIGHT
CBKDLXS08	8"	43 Lbs.	KDKITLX	5 Lbs.
CBKDLXS11	11"	54 Lbs.		
CBKDLXS14	14"	65 Lbs.		

Meets seismic requirements for the following codes:
CBC 2022
IBC 2021

Will conform to seismic code requirements for knock-down or pre-assembled application. (Contact factory for assembled version.)

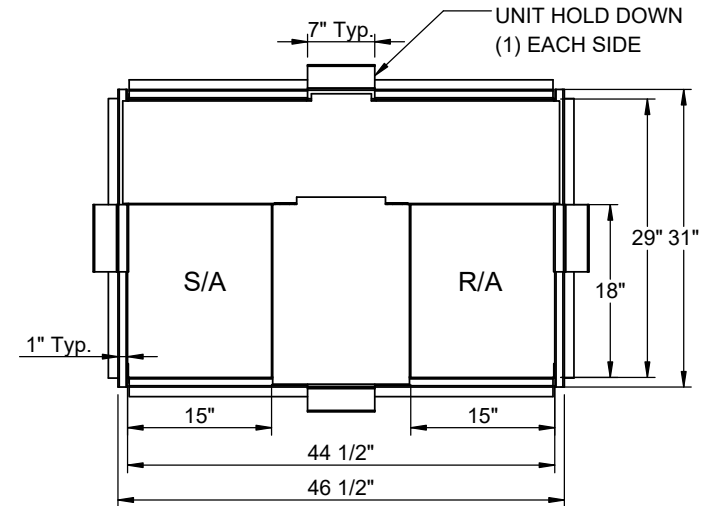
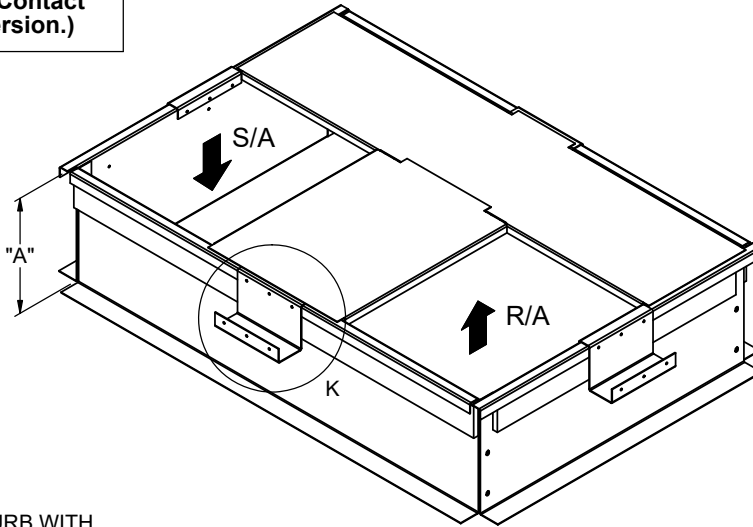

ATTACH TO CURB WITH (3) #10x 1/2" TEK SCREWS, EACH SIDE

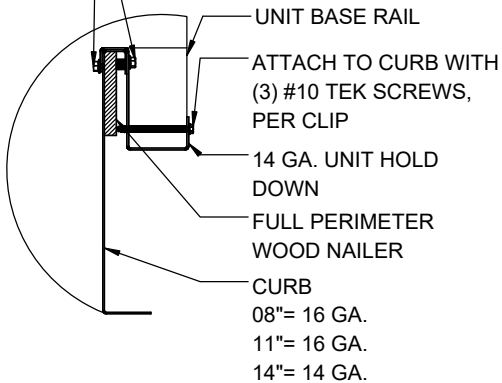

HOLD DOWN DETAIL

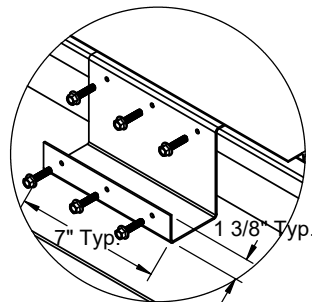

DETAIL K

1/4-20 X 3/4" GRADE 8 BOLT
(2) (A= 8")
(3) (A> 8")

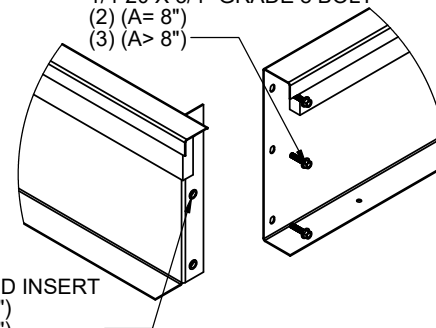

1/4"-20 THREADED INSERT
(2) (A= 8")
(3) (A> 8")

CORNER DETAIL



3847 WABASH DR.
MIRA LOMA, CA 91752

PHONE (951) 685-1101
FAX (619) 872-9799

SUBMITTED TO: _____
COMPANY: _____
JOB NAME: _____
EQUIPMENT: _____
NOTES: _____

FORM NO:
CBKD-152

PART NUMBER:
KDKITLXS SERIES

DATE:
7/14/2023

REV:
8

DRAWN BY:
JG