

FEATURES

- Roof curb perimeter made of galvanized steel.
- Gasketing package provided.
- Heat treated wood nailer provided.
- Corner flanges are pre-threaded for easy bolt on assembly.
- Pitched, adjustable height, welded, different height, isolation and calculated curbs are available.

NOTES

Attach ductwork to roof curb. Flanges of duct rest on top of curb. Support ductwork below the curb.

For wood, concrete and steel attachments see Roof Anchorage Detail, Form No. CB-60

HOLD DOWN CLIPS FOR SUNCHOICE UNITS

AV20-25, AD20-25, AE13-15, AW13-15, AH18-20, AL18-20, HV15-20

ProVent P/N	A	Est. Weight	SEISMIC CLIP P/N:	Est. Weight
CBKDSAV202508	8"	220 Lbs.	KDKITSAV2025	25 Lbs.
CBKDSAV202511	11"	250 Lbs.		
CBKDSAV202514	14"	280 Lbs.		
CBKDSAV202518	18"	400 Lbs.		

Meets seismic requirements for the following codes:
CBC 2022
IBC 2021

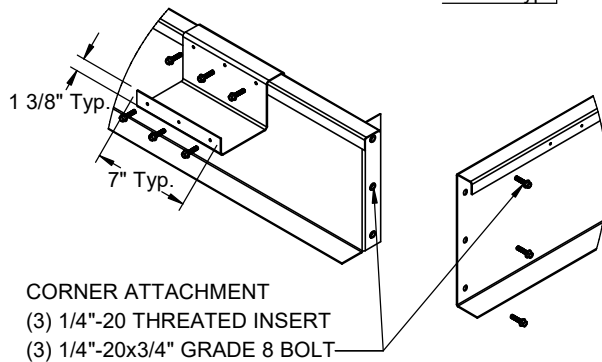
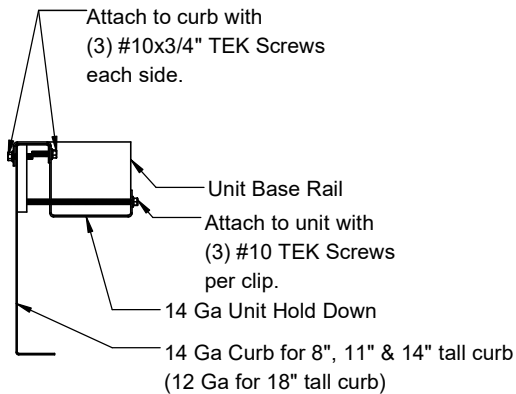
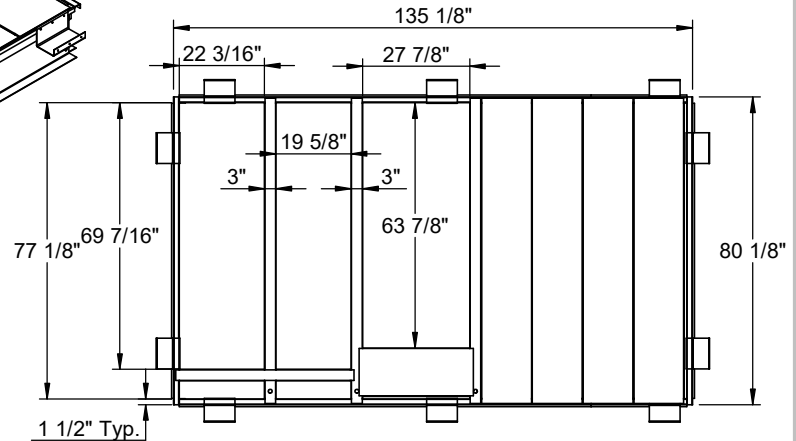
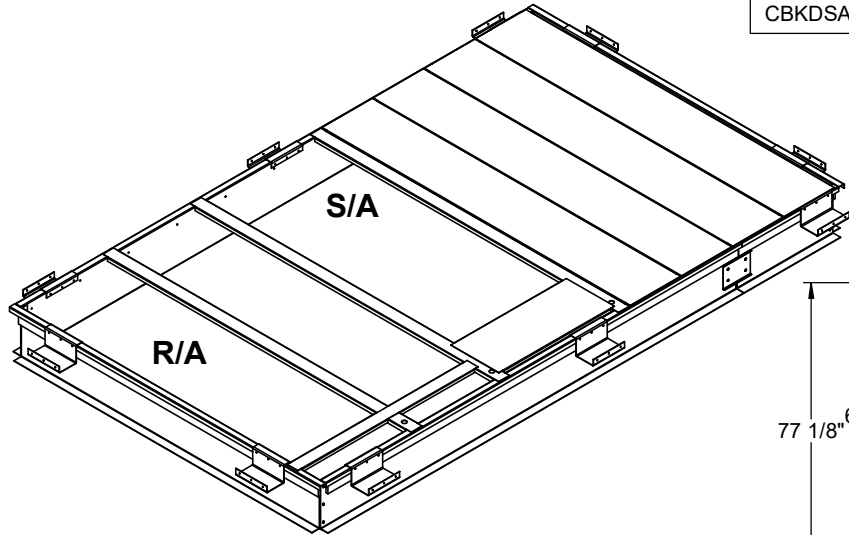

CORNER & HOLD DOWN DETAIL

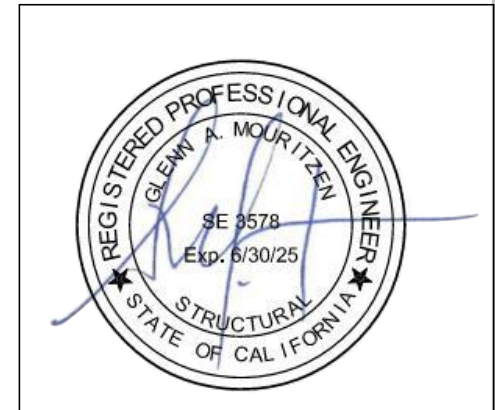

3847 WABASH DR.
MIRA LOMA, CA 91752

PHONE (951) 685-1101
FAX (619) 872-9799

SUBMITTED TO: _____
COMPANY: _____
JOB NAME: _____
EQUIPMENT: _____
NOTES: _____

PART NUMBER:

CBKD-166

PART NUMBER:

CBKD-166

DATE:

8/25/2023

REV:

2

DRAWN BY:

FMM