

FEATURES

- Roof curb perimeter made of galvanized steel.
- Gasketing package provided.
- Heat treated wood nailer provided.
- Corner flanges are pre-threaded for easy bolt on assembly.
- Pitched, adjustable height, welded, different height, isolation and calculated curbs are available.

NOTES

Attach ductwork to roof curb. Flanges of duct rest on top of curb. Support ductwork below the curb.

For wood, concrete and steel attachments see Roof Anchorage Detail, Form No. CB-60

HOLD DOWN CLIPS FOR SUNCHOICE UNITS

AV28, AD28, AE18-23, AW18-23, AH25, AL25, HV25

ProVent P/N	A	Est. Weight	SEISMIC CLIP P/N:	Est. Weight
CBKDSAV2808	8"	240 Lbs.	KDKITSAV28	27 Lbs.
CBKDSAV2811	11"	275 Lbs.		
CBKDSAV2814	14"	311 Lbs.		
CBKDSAV2818	18"	454 Lbs.		

Meets seismic requirements for the following codes:
CBC 2022
IBC 2021

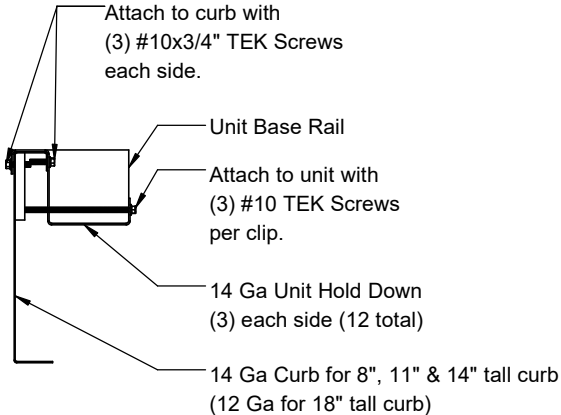
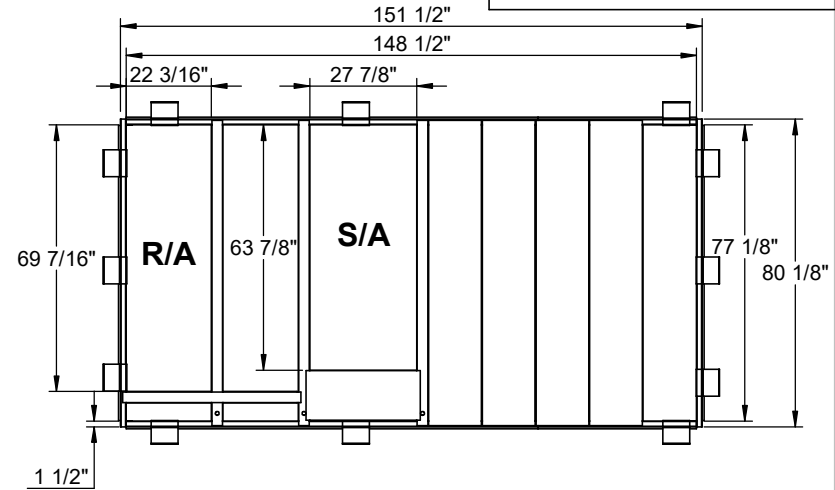
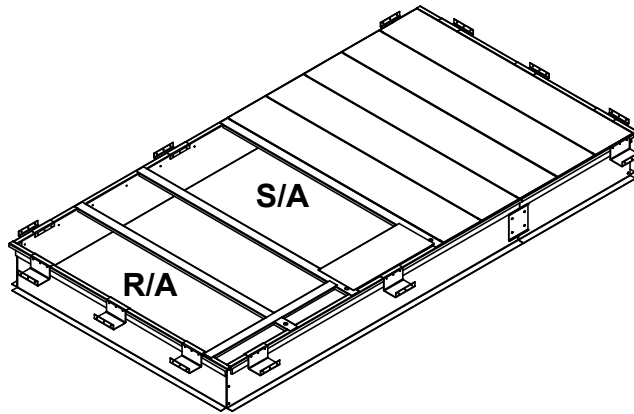

HOLD DOWN DETAIL

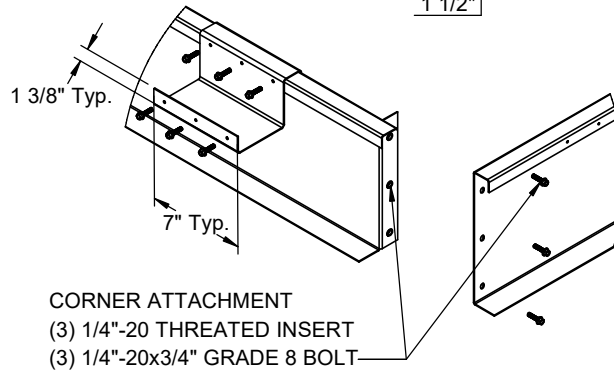

CORNER & HOLD DOWN DETAIL

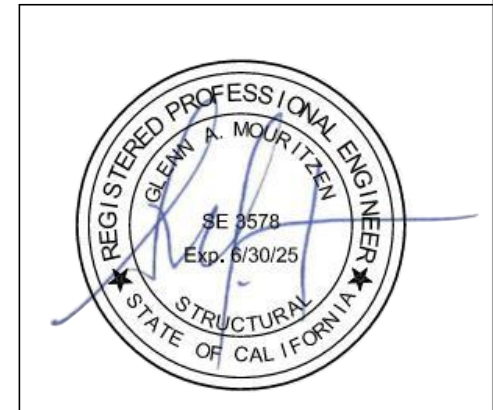

3847 WABASH DR.
MIRA LOMA, CA 91752

PHONE (951) 685-1101
FAX (619) 872-9799

SUBMITTED TO: _____
COMPANY: _____
JOB NAME: _____
EQUIPMENT: _____
NOTES: _____

FORM NO:
CBKD-167

PART NUMBER:
KDKIT28

DATE:
8/25/2023

REV:
1

DRAWN BY:
FMM