

For wood, concrete and steel attachments see Roof Anchorage Detail, Form No. CB-25A.

Will conform to wind load code requirements for knock-down or pre-assembled application. (Contact factory for assembled version.)

CALCULATED WIND ROOF CURBS FOR YORK UNITS

ZR, XN, XP 036-060
ZE, ZF 036-072

ProVent P/N	A	WEIGHT
80-265-1314	14"	117 Lbs
80-265-1318	18"	141 Lbs

Meets wind requirements for the following codes:
FBC 2020
based on ASCE 7-16.

Wind:
190 mph exposure D category III or IV building, max BLDG height: 60 ft
Kzt=1.00 max

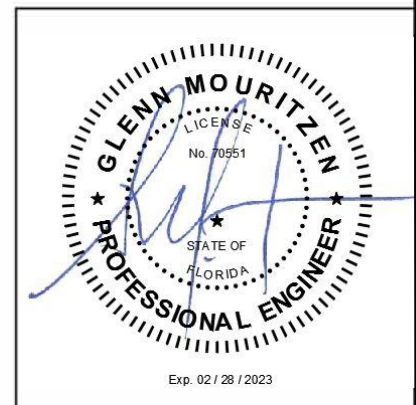
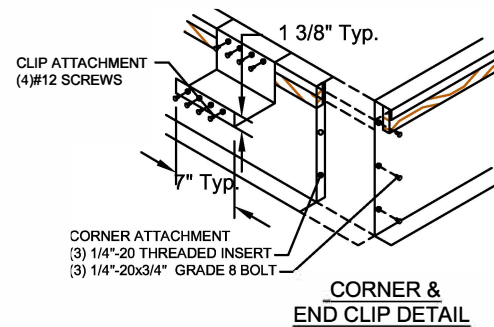
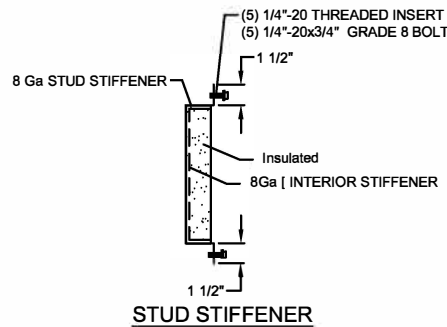
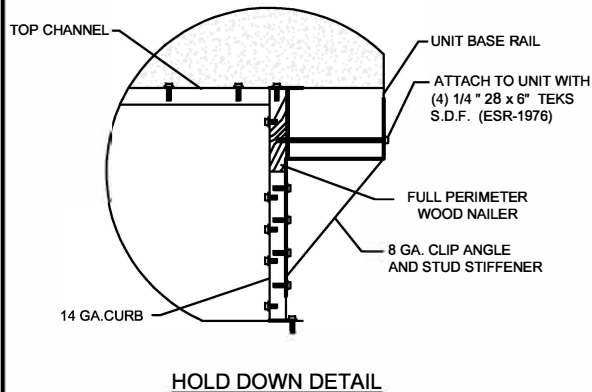
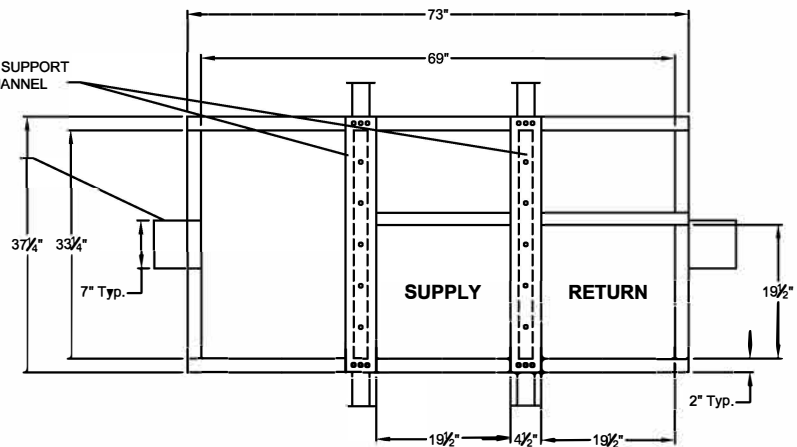
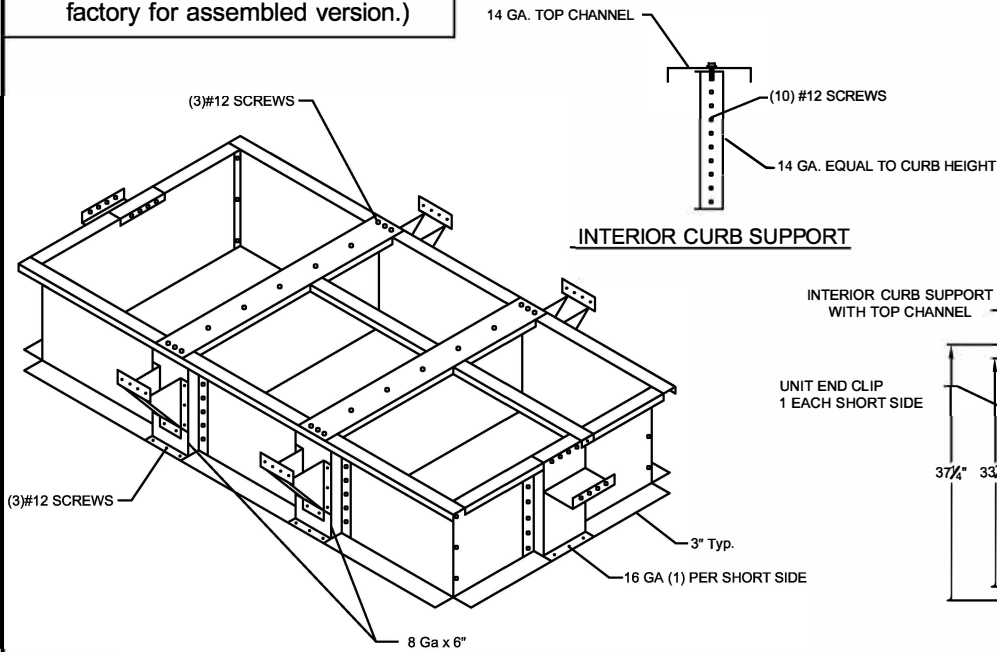

1625 DIPLOMAT DRIVE
CARROLTON, TX 75006

PHONE (972) 247-7447
FAX (972) 243-0940

SUBMITTED TO: _____
COMPANY: _____
JOB NAME: _____
EQUIPMENT: _____
NOTES: _____

FORM NO:
CBKD-94A

DATE:
3/29/2021

REV:
3

PART NUMBER:
80-265-13

DRAWN BY:
ALL