

**CALCULATED WIND
ROOF CURBS FOR YORK UNITS**

ProVent P/N	A	WEIGHT
80-265-4914	14"	129 Lbs
80-265-4918	18"	153 Lbs

P*A ALL MODELS**

Meets wind requirements for the following codes:
FBC 2020
based on ASCE 7-16.

Wind:
190 mph exposure D category III or IV building, max BLDG height: 60 ft
Kzt=1.00 max

For wood, concrete and steel attachments see Roof Anchorage Detail, Form No. CB-25A.

Will conform to wind load code requirements for knock-down or pre-assembled application. (Contact factory for assembled version.)

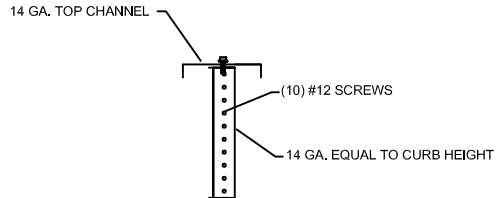

INTERIOR CURB SUPPORT

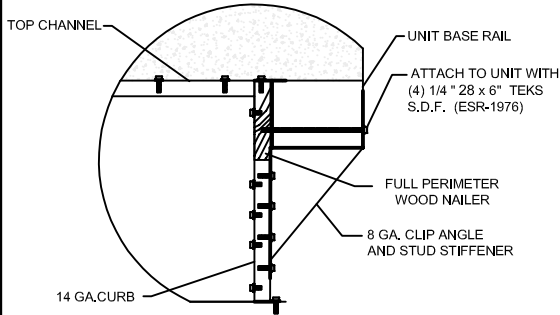
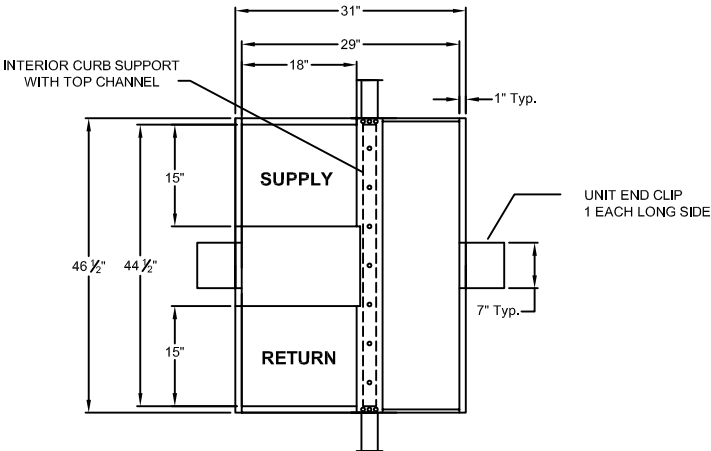
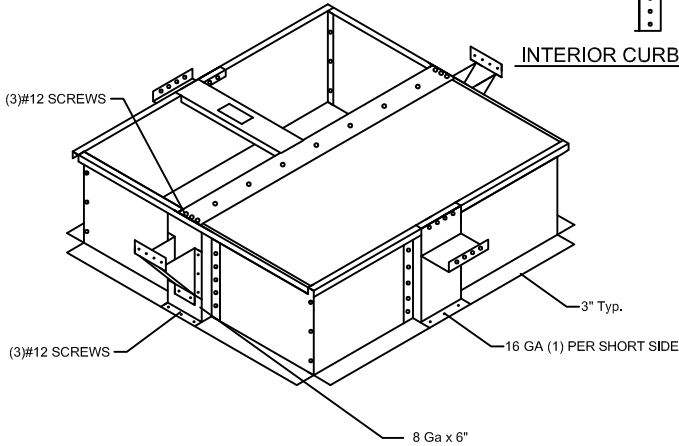

HOLD DOWN DETAIL

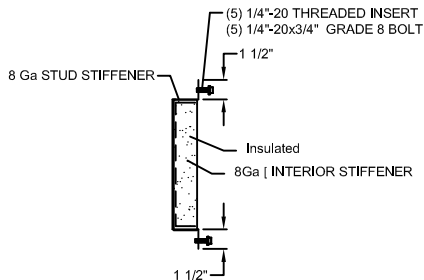

STUD STIFFENER

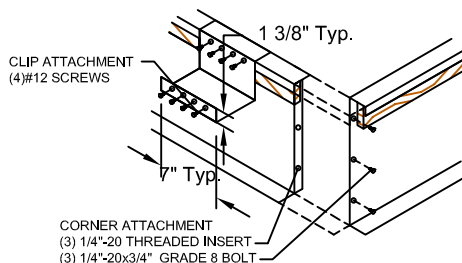

CORNER & END CLIP DETAIL

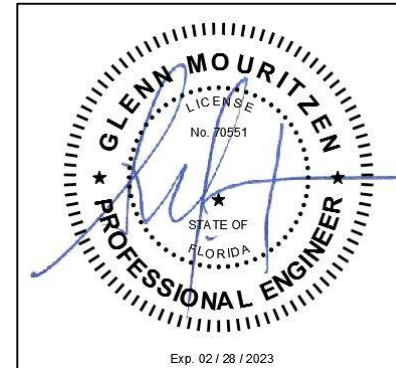

**1625 DIPLOMAT DRIVE
CARROLTON, TX 75006**

**PHONE (972) 247-7447
FAX (972) 243-0940**

SUBMITTED TO: _____
COMPANY: _____
JOB NAME: _____
EQUIPMENT: _____
NOTES: _____

FORM NO:
CBKD-160A

DATE:
3/29/2021

REV:
2

PART NUMBER:
80-265-49

DRAWN BY:
ALL